

NetWaySP4BTPL3

4-port Hardened 4PPoE (802.3bt) Switch with Integral Power on a Backplane

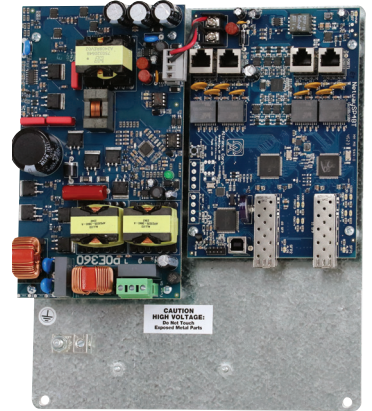

Altronix NetWaySP4BTPL3 supports up to 90W per port (360W total power) for deploying the latest high-powered IP devices in remote locations. It is equipped with two (2) 1Gb SFP ports to transmit data at long distances and four (4) 802.3bt compliant Ethernet ports. NetWaySP4BTPL3 accommodates single/multi-mode fiber or composite cable (fiber+copper) to simultaneously deliver power and data from NetWay Spectrum head-end media converters/injectors. Embedded LINQ Technology allows to monitor, control, and report power and diagnostics from anywhere.



NetWaySP4BTPL3

For unmanaged switch see model NetWaySP41BTPL3

Key Features

- Four (4) 10/100/1000 Mbps Ethernet ports rated at 90W each (limited to 360W total power)
- IEEE 802.3af, 802.3at, 802.3bt compliant
- Two (2) Gigabit SFP ports
- VLAN (Virtual Local Area Networks) subnetwork allows for the grouping together of devices for improved network traffic and higher security
- Built-in charger for sealed lead acid or gel type batteries
- CE European Conformity
- Switch and power supply are factory mounted on a backplane
- LINQ Technology:
 - Remote network management allows for camera/device reset and diagnostic monitoring
 - Provides local and/or remote access to critical information via LAN/WAN
 - Email and Windows Dashboard Alert notifications report real-time events
 - Event log tracks history

Similar products

NetWaySP4BTWPX3	Outdoor 4-port Hardened 4PPoE Switch with Integral Power in NEMA 4/4X, IP66-11 enclosure which accommodates stand-by batteries
NetWaySP4BTWP3	Outdoor 4-port Hardened 4PPoE Switch with Integral Power in NEMA 4/4X, IP66-11 enclosure
NetWaySP4BTX3	4-port Hardened 4PPoE Switch with Integral Power in NEMA 1 Rated indoor enclosure

Lifetime Warranty

Typical Application

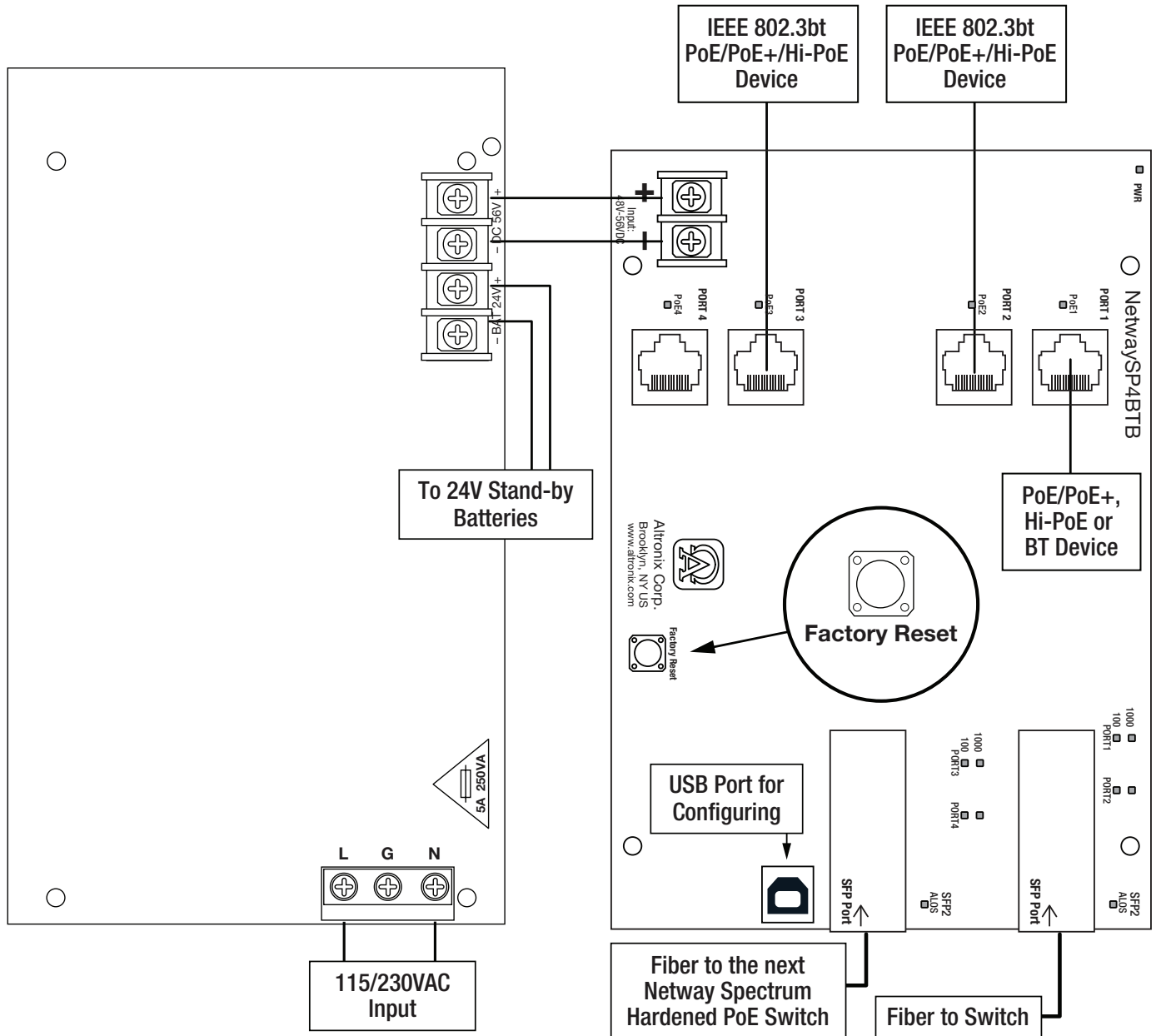

Lifetime Warranty

Altronix Corporation | 140 58th St | Brooklyn, NY 11220 USA

phone: +1 718.567.8181 | fax: +1 718.567.9056 | email: info@altronix.com | www.altronix.com

NetWaySP4BTPL3

4-port Hardened 4PPoE (802.3bt) Switch with Integral Power on a Backplane



Specifications

Input

Voltage 115VAC, 60Hz, 3.5A or 230VAC, 50/60Hz, 2A
 Input Fuse 5A/250V

Power Output

Maximum Power Four (4) PoE ports rated at 90W each, 360W total power
 IEEE 802.3af (15W), IEEE 802.3at (30W), IEE 802.3bt (90W) compliant
 Integral surge protection

SFP Ports:

Two (2) Gigabit SFP ports

Ethernet Ports:

Four (4) 10/100/1000 Mbps ports.
 Connectivity: RJ45, auto-crossover
 Wire type: 4-pair CAT5e or higher structured cable.
 Speed: 10/100/1000 Mbps, half/full duplex, auto negotiation.

Battery Charging

Type 24VDC charging circuit charges sealed lead acid or gel type batteries (require separate ventilated enclosure)
 Failover Upon AC loss, instantaneous
 Batteries are sold separately

Indicators (LED)

Individual PoE On LEDs for each port
 Individual IP Link status, 10/100/1000 Base-T/active LEDs for each port
 ALOS LED indicates fiber connection for SFP port
 Heartbeat LED indicates proper operation of the unit

VLAN:

Multiple management VLAN assignment
 802.1Q Tagged VLAN
 Up to 10 VLAN groups. ID Range 2-4095

LINQ Technology:

Remote network management allows for camera/device reset and diagnostic monitoring
 Provides local and/or remote access to critical information via LAN/WAN
 Email and Windows Dashboard Alert notifications report real-time events
 Event log tracks history

Agency Listings

CE European Conformity

Physical and Environmental

Dimensions (H x W x D approx.):

Backplane: 10.75" x 8.875" x 2.375"
 (273.1mm x 225.4mm x 60.3mm)
 Shipping: 12" x 10" x 8"
 (304.8mm x 254mm x 203.2mm)

Weight (approx.)

Product: 2.6 lb. (1.18 kg)
 Shipping: 4.0 lb. (1.81 kg)

Temperature

Operating (360W): -40°C to 45°C (-40°F to 113°F)
 Operating (240W): -30°C to 55°C (-22°F to 131°F)
 Operating (180W): -30°C to 65°C (-22°F to 149°F)
 Operating (150W): -30°C to 75°C (-22°F to 167°F)
 Storage: -30°C to 85°C (-22°F to 185°F)

Relative Humidity

85% +/- 5%

BTU/Hr (approx.)

183 BTU/Hr.

Operating Altitude:

-304.8 to 2,000m

Accessories (order separately)



SFP Modules - Hot Pluggable Transceivers

P1MM Multi-Mode SFP Module for distances up to 550m
 P1SM10 Single-Mode SFP Module for distances up to 10km
 P1AB2K Single Strand SFP Module for distances up to 2km
 P1GCE Copper SFP Module for distances up to 100m



NetWaySP1A

Ethernet over Fiber Media Converter/Repeater for Applications Requiring an Additional SFP (Fiber) Port
 NetWaySP1A PoE powered media converter/repeater converts 10/100/1000 Mbps to Fiber (1000Base-X/SX/LX).

Lifetime Warranty

NetWaySP4BTPL3

4-port Hardened 4PPoE (802.3bt) Switch with Integral Power on a Backplane



Dimensions and Drawing

Backplane Dimensions (H x W x D approximate)

10.75" x 8.875" x 2.375" (273.1mm x 225.4mm x 60.3mm)

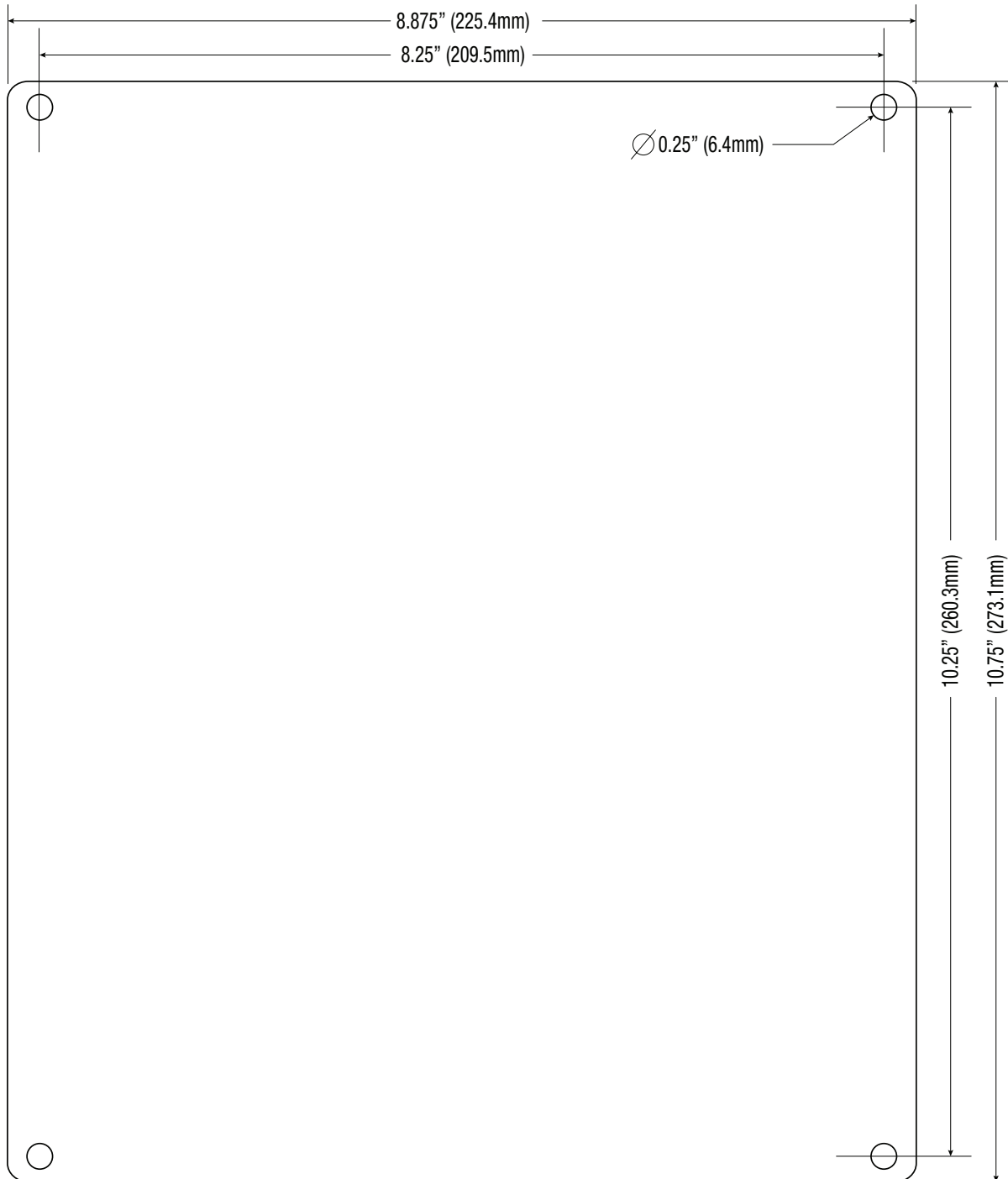

Lifetime Warranty

Altronix Corporation | 140 58th St | Brooklyn, NY 11220 USA

phone: +1 718.567.8181 | fax: +1 718.567.9056 | email: info@altronix.com | www.altronix.com